

# Head Accessories Instructions

HA-S008

- Intergrated headset system.
- Angle contact seal bearing.

- ▶ Material: Top cover Alloy 6061-T6
- ▶ Spec: Integrated 1-1/8" Upper / 1.5" Bottom  
(UP)  $\varnothing 28.6 \times \varnothing 41.8$  / (DOWN)  $\varnothing 51.8 \times \varnothing 39.5$
- ▶ Bearing: (UPPER)  $\varnothing 41.8 \times 45^\circ \times 8$  / (LOWER)  $\varnothing 51.8 \times 45^\circ \times 8$
- ▶ Weight: 78g/set

**1** The bearing base inserted into the fork tube, then insert bearing and pay attention with the taper direction and put in the end. Smear grease around the outside of the fork bearings.

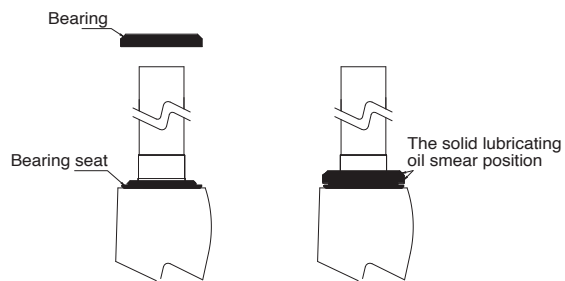

**3** After all parts are in position, check the rotation of the fork is correct, then can continue assembly headset spacers, stem, top cap...

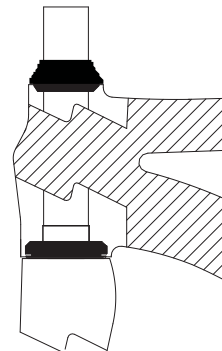

**2** Insert the fork to the frame. Smear grease around the outside of the fork bearings, then put into the fork and pay attention to the taper direction. Then put the taper spacer and the washer on the headset bearing.

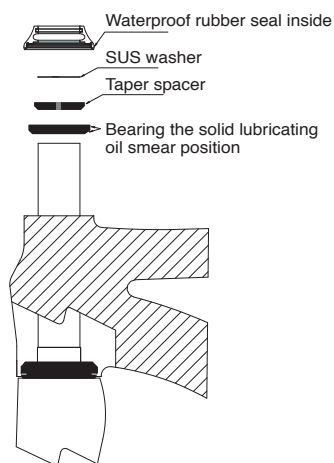

# 使用說明書

HA-S008

- 內埋式頭碗組
- 高強度壓力角培林

- ▶ 材質: 鋁合金6061-T6
- ▶ 規格: 內埋式1-1/8" (頂部) / 1.5" (底部)  
(頂部)  $\varnothing 28.6 \times \varnothing 41.8$  / (底部)  $\varnothing 51.8 \times \varnothing 39.5$
- ▶ 培林: (頂部)  $\varnothing 41.8 \times 45^\circ \times 8\text{mm}$  / (底部)  $\varnothing 51.8 \times 45^\circ \times 8$
- ▶ 重量: 78克/組

**1** 將培林底座插進前叉管，注意方向並壓到底，接著將前叉培林放入前叉管，注意角度方向，再壓到底，將前叉培林外側塗抹一圈膏狀潤滑油。

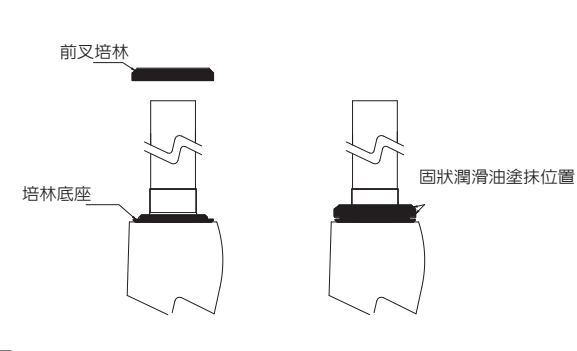

**3** 口部組件壓到底後，試旋轉是否有明顯卡住不順之情形，如果沒有，方可繼續組裝墊圈，龍頭，上蓋等配件。

**2** 將組裝完培林的前叉裝入車架頭管，頭碗培林外側塗抹一圈膏狀潤滑油後壓入前叉管，裝入時留意錐度方向。接著依序將錐度切溝墊圈以及白鐵墊片裝入前叉管，裝入時留意錐度方向，最後將頭碗蓋裝入把內埋件蓋住。

